

www.radiopharos.it

198.50

WJ-8888 RECEIVER

100



FEATURES

The WJ-8888 is a highly versatile HF receiver which provides exceptional signal handling capabilities over the frequency range of 500 KHz to 30 MHz. The receiver has three operating modes: Local, Remote and Memory. In the Local mode, the receiver is tuned manually by the operator. In the Remote mode, the receiver accepts and stores a digital word which controls the tuned frequency, detection mode, gain mode, IF bandwidth, RF gain level and BFO frequency. When operated in the memory mode, tuned frequency and mode of operation data can be loaded by the operator into a four-channel memory (expandable to 16 channels in four channel segments) and accessed at a later time when requested by the operator.

The receiver is designed for the reception of AM, FM, CW, ISB, LSB, and USB emissions. Up to six IF bandwidths may be selected via front panel push-button switches. Four standard IF bandwidths of 0.5, 2, 4, and 8 KHz are supplied with two IF bandwidths reserved for customer selection. The optional IF bandwidths are 0.2, 1, 3, 6, 12, or 16 KHz.

Additional features of the WJ-8888 include a unique variable rate manual tuning control where the tuning rate varies in proportion to the rotational speed of the tuning control knob. This

permits rapid and accurate tuning to signals of interest. Other features include automatic switching of suboctave preselection filters for optimum intermodulation characteristics and a synthesized local oscillator for maximum receiver stability.

The tuned frequency of the receiver is displayed on a front panel seven-digit LED readout. Resolution of the display is 10 Hz over the entire tuning range. Three selectable gain control modes are provided: Manual, Normal AGC, and Hold AGC. A meter on the front panel indicates relative signal strength or calibrated line audio output level. Front panel controls include: Main Tuning, RCVR Control, IF Bandwidth Select, Gain Mode Select, Detection Mode Select, RF Gain, ISB Audio Select, Audio Level, Squelch, and Variable BFO Control.

Audio output is available at a front panel phone jack or a rear panel connector. An audio squelch circuit mutes the receiver audio output in the absence of incoming signals below the threshold set by the front panel Squelch Control. The receiver also provides two simultaneous ISB outputs and a predetection IF output of 455 KHz. The 64-bit TTL-compatible I/O data is interfaced to the unit via a connector on the rear panel.

For Further Information Please Contact:

WATKINS-JOHNSON COMPANY

700 Quince Orchard Road, Gaithersburg, Maryland 20760
(301) 948-7550 TWX: 710-828-0346 TELEX: 89-8402 CABLE: WJCEI

Printed in U.S.A.

SEPTEMBER 1973

Specifications subject to change without notice.

To enhance the receiver's versatility, a number of options are available in addition to the customer selected bandwidth options. The receiver may be ordered without the preselection suboctave filters when the receiver is used in a low signal density environment or when preselection is accomplished by the associated antenna network.

An optional logarithmic IF amplifier is available to provide a log video output to a rear panel BNC connector. The standard I/O interface module accepts a standard 64-bit serial data word. As a customer selected option,

transmission of the 64-bit data word can be serial or parallel, synchronous or asynchronous. In systems where master/slave or remote operation of receiver groups is desired, the remote/slave receivers can be supplied without front panel control and frequency readout.

The WJ-8888 is designed for mounting in a standard 19-inch equipment rack and occupies 5.25 inches of vertical space. The standard unit operates on 115/220 Vac $\pm 10\%$, 48-62 Hz. An optional model is available for operation from a 400 Hz, 115/220 Vac prime power source.

SPECIFICATIONS

Tuning Range	0.5 - 30 MHz
Preselection	Sub-octave filters automatically switched
Input Impedance	50 ohms, unbalanced
Input V.S.W.R.	2:1, maximum
Oscillator Radiation	10 μ V or less at receiver input
Noise Figure	15 dB, maximum
IF Bandwidths, (3 dB)	4 Bandwidths supplied, 6 positions available
Normally supplied	0.5, 2, 4, and 8 kHz
Optional	0.2, 1, 3, 6, 12, or 16 kHz
Detection Modes	AM Noise Limiter, AM, CW fixed, CW variable, USB, LSB, ISB, FM
Gain Control Modes	Manual, Normal AGC, Hold AGC
AGC and Manual Range	100 dB, minimum, for input signals above 2 μ V
AGC Threshold	2.0 μ V, minimum
AGC Attack Time	20 ms
AGC Release Time	Normal AGC, 0.1 seconds; Hold AGC, 3 seconds
Control Modes	Local, Memory, and Remote
Sensitivity	
AM Sensitivity*	The input signal levels specified in Table 1, 50% AM modulated at 400 Hz rate will produce a 10 dB (S+N)/N ratio at the audio output.
CW Sensitivity	The CW input signal levels specified in Table 1 will produce a 16 dB (S+N)/N ratio at the audio output.
FM Sensitivity*	The input signal levels specified in Table 1, FM modulated at a deviation equal to 30% of the IF bandwidth, at a rate equal to 10% of the IF bandwidth or 400 Hz, whichever is less, will produce a 17 dB (S+N)/N ratio at the audio output.
LSB, USB, ISB	0.50 μ V for 10 dB (S+N)/N or greater in 2.4 kHz bandwidth.
Outputs	
Audio	1 mW, minimum, into 600 ohms at the specified sensitivity levels
Audio Distortion	Less than 5%
Audio Amplifier Frequency Response	Within 3 dB from 100 Hz to 15 kHz
Phones	10 mW, minimum, into 600 Ω front panel adjusted
ISB	Two, each provides 1 mW, minimum, into 600 Ω at 2.0 μ V input level

* For the 0.2 kHz, 0.5 kHz, and 0.8 kHz bandwidth, AM or FM sensitivity is not defined.

IF	455 kHz, 50 mV, minimum, at the above sensitivity levels
IF Rejection	Greater than 100 dB
Image Rejection	Greater than 100 dB
Unwanted Sideband Rejection	50 dB at 350 Hz into unwanted sideband
Intermodulation	
Third Order Input Intercept Point	+20 dBm, minimum, for signal separation >30 kHz
Second Order Input Intercept Point	+60 dBm, minimum
Cross Modulation	With desired signal at 50 μ V, an undesired signal at 0.5 volts greater than 30 kHz away, AM modulated 30% produces an output at least 30 dB below the output level of desired signal.
Tuning Speed (Remote)	Less than 5 ms
Manual Tuning	Variable rate, depending on rotation speed of tuning knob. Rate is linear at low rotational speeds and logarithmic above one revolution per second. The minimum tuning increment is 10 Hz.
Frequency Selection (Local)	Single tuning knob
Frequency Stability	6 x 10 ⁻⁸ per day, 2 x 10 ⁻⁶ per year
Frequency Display	7 Digit, LED (dot matrix) display
Remote Control	The internal information is organized as a serial 64-bit word with synchronous format. An asynchronous format is also available as an option.

Bit Organization

1 Spare	1 Spare
1 AGC Dump	11 BFO Frequency
26 Frequency	1 Spare
2 AGC Mode	7 RF Gain
3 IF Bandwidths	1 Fault
3 Detector Mode	7 Signal Level

Memory Mode	Other remote control formats can be accepted using internal optional interface cards. Four channel memory capacity supplied. The entire 64-bit word is stored. Complete operating mode of the receiver may be internally stored and recalled later.
Optional Memory	Up to a total of sixteen channels in groups of four channels.
AC Power Interrupt	While the receiver is in the Local Mode, all the above functions are placed in a separate memory and reappear when power returns.
Non-Remote Control Functions	Phone level, squelch memory channel select and RF/Audio meter
Signal Meter	Indicates RF input signal level or line audio output level
Size	16" wide or 19" wide, 5-1/4" high and 16" deep
Weight	Approximately 40 pounds
Operating Temperature	0° - 50° C (32° F to 122° F)
Power Consumption	Approximately 80 watts
Input Power Requirements	115/220 Vac \pm 10%, 48-62 Hz. 400 Hz operation available as an option.

TABLE 1
SENSITIVITY

IF Bandwidth kHz	Input Level	
	Microvolts	dBm
0.2	0.28	-118
0.5	0.45	-114
1.0	0.64	-111
2.0	0.89	-108
3.0	1.2	-105.5
4.0	1.3	-105
6.0	1.7	-102.5
8.0	1.8	-102
12.0	2.4	-99.5
16.0	2.5	-99

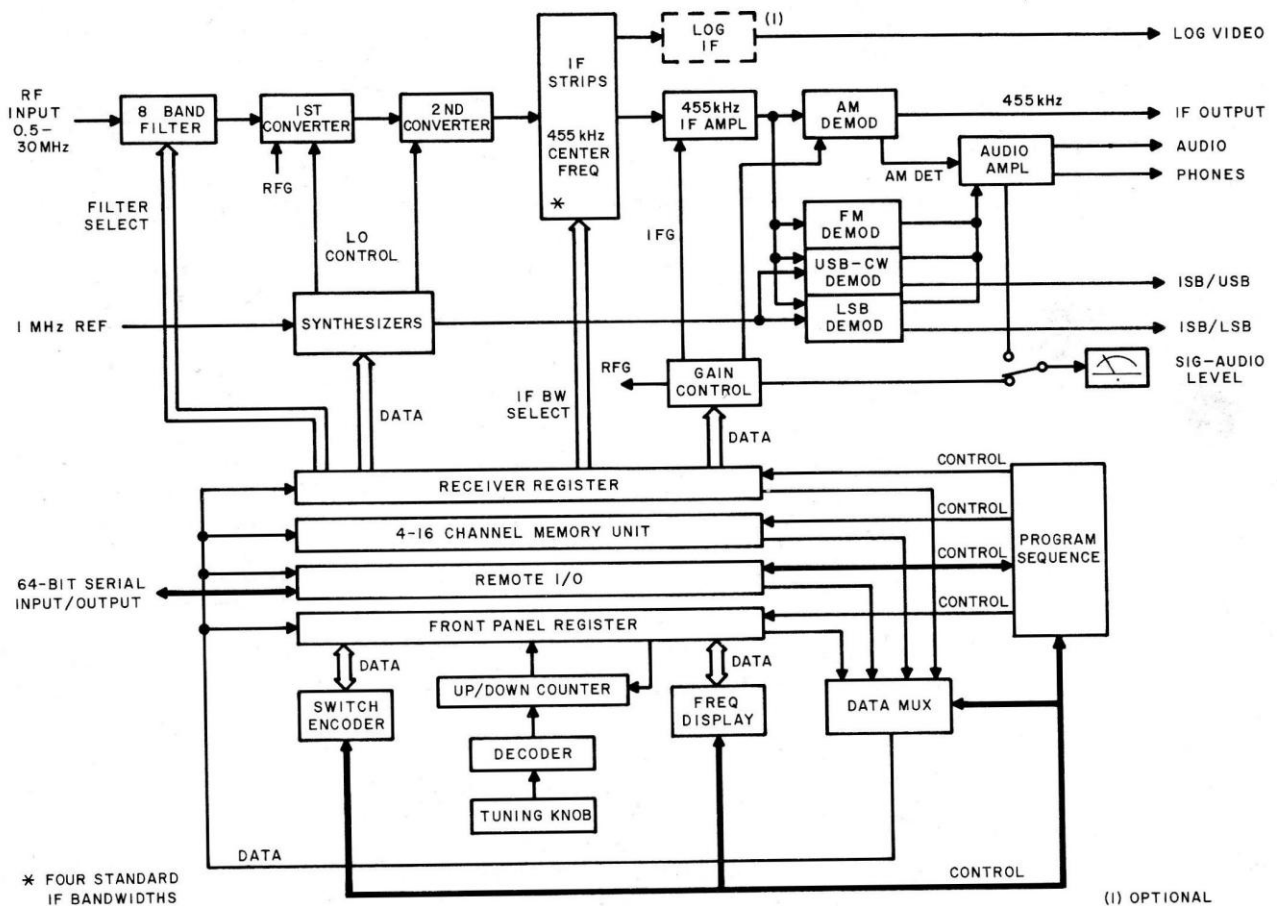

WJ-8888 RECEIVER-SIMPLIFIED BLOCK DIAGRAM